



AdventistSat.com

1-888-393-4673

<http://www.AdventistSat.com>

sales@AdventistSat.com

service@AdventistSat.com

AMC 4 Dish Aiming Information for Zip Code _____

Elevation	_____°
Azimuth, Magnetic	_____°
Feedhorn Rotation	_____°

Do It Yourself Guide for Adventist Satellite Installation System: Fortec Lifetime Ultra / SatelliteAV 36" Dish

Table of Contents

1. Selecting the Best Dish Antenna Location
2. Mounting the Dish Antenna
3. Connecting the Satellite Receiver
4. Aiming and Fine Tuning the Dish Antenna
5. Completing the Installation
6. General Site Survey – Can I receive the Adventist Channels at my house?
7. FAQ – Frequently Asked Questions and Troubleshooting
8. Elevation Angle Calculator

Please read these instructions completely before attempting to install your system!

If you feel comfortable with drilling holes in the walls and/or roof of your home, climbing ladders, attaching wires to the utility ground according to NEC and local codes and following step-by-step instructions, you might consider installing your own system. **The satellite is located over 23,000 miles away and the installation does require precise tuning and a great deal of patience to correctly install.** Have you recently installed a light switch, ceiling fan, basketball hoop and programmed a VCR? If not, this project might not be a good time to hone your mechanical and electrical skills!

Please contact Adventistsat.com at 800-393-4673 or 916-677-0720 if you would like to schedule a basic professional installation in the US or CANADA.

1. Selecting the Best Dish Antenna Location

Using the aiming coordinates from the last page of this guide along with a compass and angle finder, locate a dish mounting position. While facing the direction of the satellite, reference the magnetic azimuth (compass angle) and elevation. The dish **must** be located with a clear line of sight to the satellite with no obstructions. Satellite signals will not pass through leaves, limbs, overhangs, glass, etc.

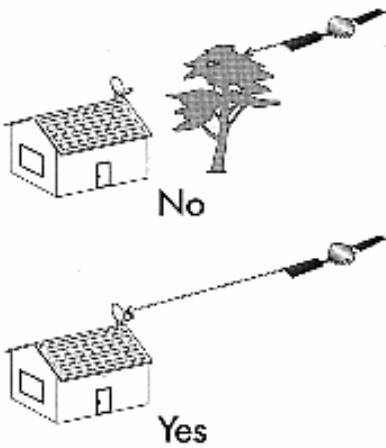

If no suitable location can be found on a wall or roof, consider alternative mounting locations such as setting a galvanized pipe set in cement located in a clearing. Do not mount the dish on a wooden post or high up on a tree, as this will not provide a stable platform. The coax cable run should be as short as possible. The included grounding block and wire should connect to the utility ground according to NEC and local electrical codes.

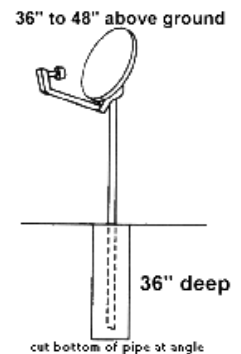
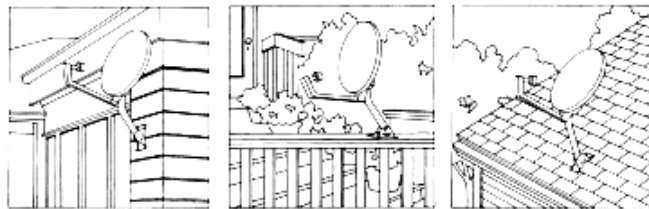

2. Mounting the Dish Antenna

Secure the dish post. Be sure that the lag bolts on the base plate are screwed into the rafters or wall studs and not only into the sheathing. This will provide a solid base for the remainder of the installation. Apply silicone caulking or other sealant to all lag bolts and cable access holes to prevent water leakage.

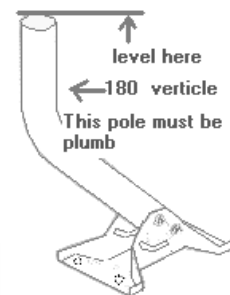
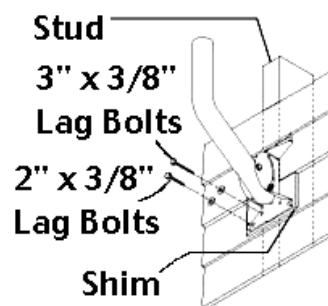
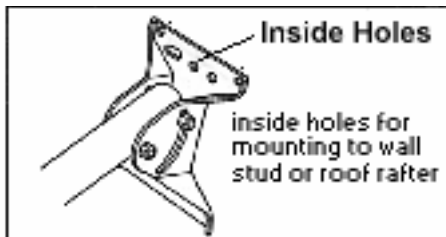
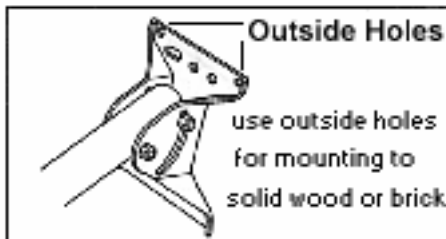

The slightest movement of the installed dish and mount will result in degraded quality and loss of reception! Level the mounting post using a level (two-way post levels simplify the installation process). If the mounting post is not level, the aiming process will be very difficult!

Assemble the dish antenna using the A type configuration if the satellite elevation angle is 20 – 50 degrees and the B type if the elevation is 50 – 90 degrees. Attach the lnb (small gray box with a white cap) to the feed arm. Set the lnb rotation as specified in the aiming coordinates and slide the lnb out away from the reflector then semi-tighten the attaching bolt and set screw.

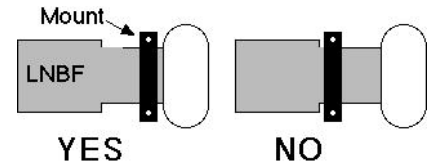
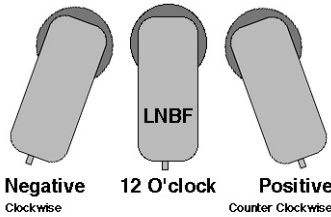

Adjust the dish elevation to the correct angle using the A or B scale located on the side of the mount then semi-tighten the elevation fastening bolts. Place the dish on the mounting post and aim towards the magnetic azimuth using the enclosed compass. Metal and electrical devices including the metal of the dish and mounts will affect the compass readings. Be sure to take the azimuth readings with the compass located a distance away from these types of influences and check this reading in several locations to ensure a correct reading. Semi-tighten the azimuth fastening bolts.

3. Connecting the Satellite Receiver

The easiest way to aim the satellite dish is to temporarily place the satellite receiver connected to a small television at the dish antenna mounting location.

DO NOT ATTEMPT THIS IF IT IS RAINING OR THE GRASS IS WET. Using a satellite meter will simplify any installation! Remove the satellite receiver and remote control from the packaging. Install the included batteries into the remote control. Connect a coaxial cable from the lnb on the dish antenna to the IF INPUT port on the back of the satellite receiver. Finger tighten these connections. **Never use a wrench to tighten the lnb connection as this will severely damage the unit and void the warranty!**

Connect a short coaxial cable from the TV OUT port on the back of the satellite receiver to the antenna input of the television then set the channel 3/4 selection switch on the back of the satellite receiver to an unused channel in your area (usually channel 3) and turn the television on and set it to the matching channel. Plug the electrical cord into the satellite receiver and then into a surge protected power strip. The receiver will automatically power. Press the **Channel Up** or **Down Arrow** button to choose **3ABN English** (this is the strongest channel on the satellite which will help you find the signal faster).

4. Aiming and Fine Tuning the Dish Antenna

Press the **SIG** button on the remote to display the signal strength screen which displays indicators of level and quality. When the dish is aimed correctly the **UNLOCK** indicator will change to **LOCK** and the **Quality Bar** will turn green and display a quality level.

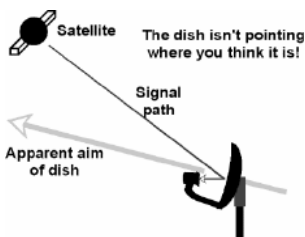

Offset dish antennas are aimed at an elevation that is higher than the angle that the face is directed. While you or an assistant observe the bar meters, slowly make minute azimuth (left or right) adjustments first in one direction (up to 10 degrees), if necessary sweep the other direction until a green bar appears in any strength on the quality meter. Wait 5 - 10 seconds between each adjustment to allow the receiver to process the information and update the strength and quality

displays. If no green bar appears, adjust the dish up or down one degree of elevation and repeat the sweep process. When the receiver is connected to the lnb the strength level meter will always display a signal. If the dish is aimed at the incorrect satellite, the meter will display a high signal, but the quality meter will never turn green. (HINT: Sweep extremely slow as a movement of just 1/2 of a degree can result in a perfect or no signal.) This process may need to be repeated many times in order to precisely aim and peak the quality of the signal. Once the correct satellite is located, make minute adjustments in elevation and azimuth until maximum signal is indicated on the quality bar with the corresponding numerical readout.

Quality readings should be in 75 to 90% to insure optimum picture and sound on this receiver. The higher the quality, the better the reception. If the signal becomes weak the picture will break up into little squares and the sound will become garbled and choppy or both will disappear completely!

Fine tune the installation by pressing the **SIG** button again to exit the signal strength screen then use the **Channel Up Arrow** button to select LLBN (this is the weakest signal of the Adventist channels). Once again press the **SIG** button to display the signal strength meter and make small adjustments to the elevation and azimuth angles to peak the quality level. Tighten the elevation and azimuth nuts and bolts while continuing to observe the signal meters. If the signal levels drop during the tightening process, additional adjustments will need to be made. Peak the signal strength level and quality by slightly rotating the lnb and / or moving the lnb towards or away from the dish. Once the signal is peaked, tighten the LNBF mount bolt and screw. Press the **SIG** button to hide the signal strength meter. The dish installation is now complete.

5. Completing the Installation

Carefully route the coax cable from the dish to the satellite receiver. Secure all cables using appropriate cable clips and nylon zip ties. Avoid using wire staples as they can dimple or penetrate the cable and can cause loss of signal! Do not tightly bend the cables and leave drip loops and cable loops as needed. Remember to seal all exterior wall and/or roof holes with a quality sealant or silicone caulking. Install the grounding block and grounding wire following all NEC and local electrical codes.

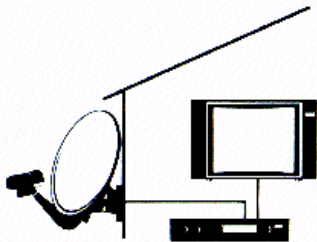

DO NOT USE EXISTING CABLING OR THE PREINSTALLED HOUSE CABLING. ALWAYS CONNECT THE COAXIAL CABLE DIRECTLY FROM THE LNB ON THE DISH TO THE RECEIVER "IF IN" PORT - PASSING ONLY THROUGH THE GROUND BLOCK. **SEVERE DAMAGE WILL RESULT IF THE RECEIVER IS HOOKED TO DEVICES OTHER THAN THE LNB.** THE OUTPUT OF A SINGLE LNB SHOULD ONLY FEED ONE LOCATION AND THERE CANNOT BE ANY TV SPLITTERS OR OTHER DEVICES IN LINE UNLESS APPROVED FOR SATELLITE INSTALLATIONS.

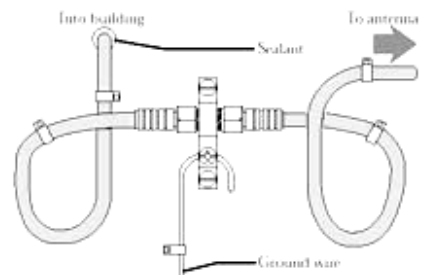

The basic installation is now complete. Connecting the satellite receiver audio outputs to the television, VCR and/or stereo inputs can enhance the audio. Connection of the video or s-video outputs to the VCR and/or television inputs will result in improved video! Consult the owner's manual for additional operational information.

Will a Hope Channel Satellite Dish Work at Your Home?

6. General Site Survey

To get a signal, the satellite dish must be pointed directly at the satellite, with NO obstructions between the two. This means NO trees and NO buildings. Take into consideration future tree growth, house remodeling or additions and new construction in your area.

The satellite signal WILL NOT PASS through leaves or branches.

The satellite signal WILL NOT PASS through glass; don't try to install your dish indoors!

Where Is The Satellite, Anyway?

The satellite is always located south of Texas. That means if you live in Miami, you must have a clear line of sight to the southwest; if you live in San Francisco, you must have a clear line to the southeast.

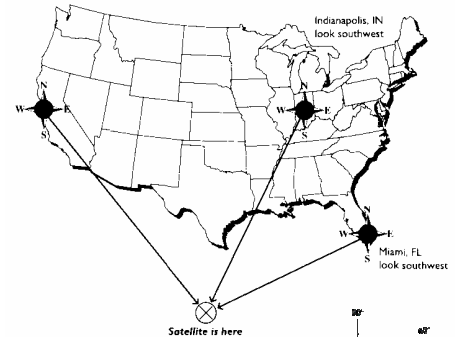

How High Up in the Sky is the Satellite?

Depending on where you live, the satellite will be at an elevation angle between 30 and 60 degrees. Southern US point more toward 60 degrees; northern US point more toward 30 degrees. The average elevation is 45 degrees.

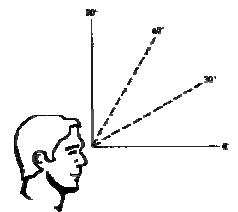

Northern Canada, Alaska and Hawaii elevation angles can be very low on the horizon. Please contact AdventistSat.com at (888) 393-HOPE (4673) for more aiming assistance.

Finding a Clear Line of Sight

1. Go outside and locate at least one site on your property that has a clear view to the satellite. You should be reasonably certain you are pointing toward Texas (unless you're in Texas, in which case you should be looking due south). You may want to use a map.
2. Imagine an arc ranging from 30 to 60 degrees above the horizon.
3. Do you have at least one clear view to the satellite? Remember, no trees, leaves, buildings, or windows can be between the dish and the satellite.

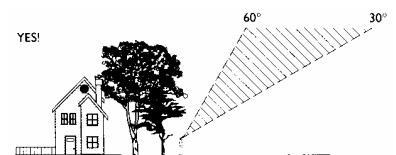

If the answer is **NO**, your site may be unsuitable for installing the satellite system.

If the answer is **MAYBE**, you may want to contact the technical department at (888) 393-HOPE (4673) for information about having a professional installer conduct a thorough site survey.

If the answer is YES, your site should be suitable for installing the system.

7. FAQ – Frequently Asked Questions and Troubleshooting

The receiver displays strong Signal Strength Level, but has no Quality on all channels.

The dish might be pointed at the wrong satellite or there is an obstruction in the line of sight between the dish and the satellite. Mounting mast may have moved or is loose.

The picture breaks up into big blocks and the audio is garbled.

The antenna might not be aimed correctly. Satellite view partially obstructed. Damaged coax or connections.

The meters do not display any signal level or quality.

Coax connected from LNBF on dish to LNB In on back of receiver. Bad coax, connectors or LNBF.

No lights on receiver.

Check power plug make sure that it is plugged into an electrical outlet.

Satellite receiver has a channel number on front panel, but TV displays snow.

Tune TV to channel 3 or 4.

Local or cable TV channels are fuzzy and channel number is displayed on front panel.

Turn off the satellite receiver when watching local or cable channels.

Satellite receiver front panel buttons turn on/off and change channels, but remote doesn't work.

Check batteries, remote needs clear line of sight to the receiver panel display window.

No audio on any satellite channels.

Set satellite remote control audio up to 75% and use TV volume control to change volume.

Satellite receiver won't respond to remote or front panel buttons.

Unplug receiver from electrical outlet for 10 seconds then plug the receiver back in and turn it back on.

Satellite receiver displays "No Signal" only during very hot or cold weather.

LNBF is affected by the temperature extremes. Replace LNBF.

Picture breaks up during rain and snow

Heavy rain or clouds may affect the strength of the satellite signal. A properly installed dish will rarely lose signal during extreme weather. Snow or ice build up can interfere with the satellite signal. Mount the dish where snow can be gently brushed off. Dish covers and heaters are available for locations with regular ice and snow accumulations.

Most of the channels have strong Signal Quality, but LLBN signal quality is poor or the receiver displays "No Signal".

LLBN has a weaker signal than the other Adventist channels and may display a low signal quality or no signal. Installations often need to be fine tuned to receive this weaker station. Place the receiver on the LLBN channel. Press the SIG key and make slight adjustments to the antenna elevation, azimuth and the LNBF rotation and distance from the reflector to peak the quality.

Are more channels available than are preprogrammed?

Many more channels are available for viewing on this and other satellites. This receiver is capable of automatically programming these additional TV and Radio services. Many free national and international services are available. *Do this at your own risk, as AdventistSat.com will only provide the two-year free technical support for the reception of Adventist programming.* To receive additional programming from the AMC4 satellite you may use the power scan feature. Press the **Menu** key to enter the User Setup Menu then the **Right Arrow** to select the Installation Menu. Press the **Down Arrow** 4 times to select POWER SCAN then press **OK**. Press the **Up Arrow** to select SCAN FTA then press **OK**. The receiver will scan the entire satellite for new channels then save them into the channel list.

ANGLE FINDER

1. Print Angle Finder
2. Fold Angle Finder Outside Edges
 - Use Guide Arrows
 - Fold in Order 1, 2, 3 & 4
 - Use Tape To Secure Folds
3. Follow Printed Instructions

